

Superstar Manual



ARTCOUSTIC  
of  
Denmark

## Better, by Design

Usually in the world of sound and cinema, you have to choose between great design and great performance. There are exceptions of course, but in general, that's the way it is. Especially when it comes to loudspeaker design; if it looks good, it's unlikely to sound good, and for some reason, if it sounds good, it very rarely looks good. At Artcoustic, we have never accepted this idea. So when you buy an Artcoustic speaker, you get the best of both worlds. They sound great, because we have brought years of knowledge and experience to bear on designing speakers that reproduce music and movie soundtracks faithfully, accurately and in breathtaking detail. And they appeal to the eye because we came up with the idea of interchangeable screens. Quite simply, you choose how your speakers look. We have a wide portfolio of beautiful patterns and designs, and of pictures from artists and photographers including an array of iconic images from the Getty Images Gallery. We also offer a bespoke printing service where you can provide an image, for example a commissioned artwork or photograph, and we print this on to screens for your speakers. As the screens are interchangeable the image can be changed whenever you like. You choose how your speakers look, so they always complement rather than conflict with any interior design.

Going back to the roots of traditional Danish loudspeaker design, Artcoustic has transformed the conventional loudspeaker with a modern look. We strive for perfect sound reproduction, using only the most advanced technology available. Artcoustic is a state-of-the-art product, a loudspeaker that is among the elite of high-end loudspeakers worldwide. The remarkable dynamic range and efficiency, far higher than conventional hi-fi designs, make Artcoustic loudspeakers the perfect solution for both high-end residential and commercial applications.

The Artcoustic loudspeaker is the first and only of its kind, combining a unique mix of art and design with the science of acoustics.

**Great looks, great sound. Great news.**

## Residential



## Professional



## Commercial



## Artcoustic gallery

Artcoustic hand-picks artists from around the world and invites them to create exclusive artworks for the Artcoustic Artist Portfolio. The Artcoustic Artist Portfolio is available for viewing at all specialist Artcoustic dealers. View our latest selection on the Gallery section of the Artcoustic web site. Each artwork/design is produced as a digital print and hand made into a screen.

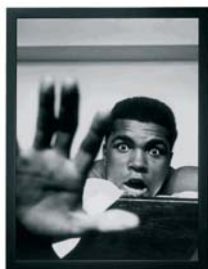

# Artcoustic product range



Diablo Target  
H:200 W:270 D:69mm



Diablo Monitor  
H:330 W:270 D:73mm

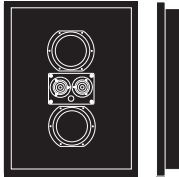

DF65-50  
H:650 W:500 D:97mm

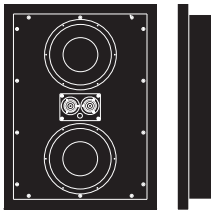

DF75-55  
H:750 W:550 D:133mm

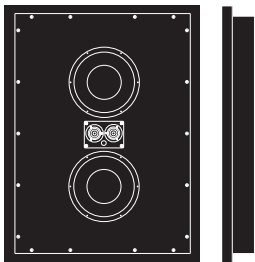

DF100-75  
H:1000 W:750 D:133mm

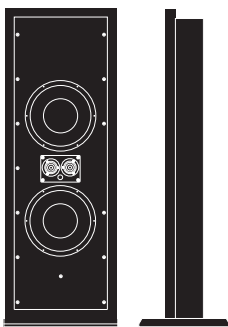

DFF120-43  
H:1200 W:430 D:153mm

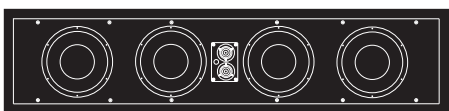

DFC150-36  
H:1500 W:360 D:133mm



Linux Duo Storage Cabinet  
H:312 W:1060 D:538mm



Diablo C-1  
H:126 W:650 D:85mm



DF-Multi 42 inch  
H:150 W:1030 D:74mm



DF-Multi 50 inch  
H:150 W:1220 D:74mm



DF-Multi 60 inch  
H:200 W:1500 D:85mm



PA-1800 3 channel  
professional power amplifier



PA-260 2 channel  
professional power amplifier

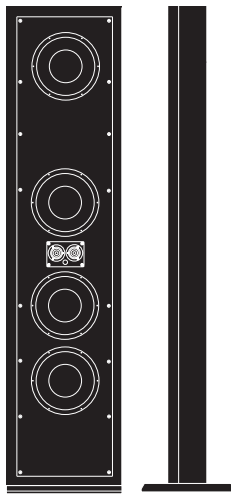

DFF180-43  
H:1800 W:430 D:153mm

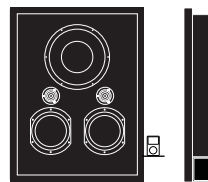

Superstar  
H:650 W:500 D:130mm

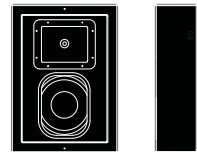

Spitfire Venue PA. Monitor  
H:500 W:360 D:160mm

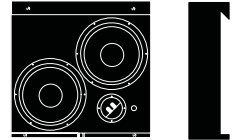

Diablo Sub Panel  
H:500 W:500 D:144mm

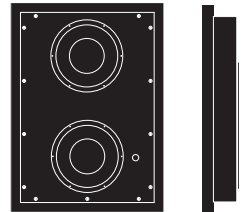

DFS75-55 Subwoofer  
H:750 W:550 D:133mm

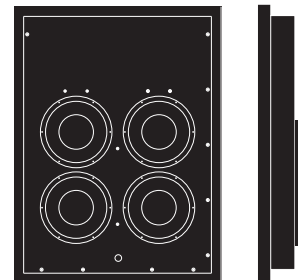

DFS100-75 Subwoofer  
H:1000 W:750 D:133mm

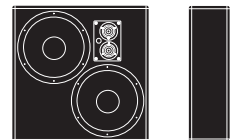

Spitfire Studio Monitor  
H:500 W:360 D:150mm

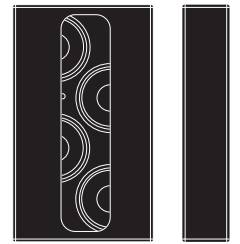

Spitfire Subwoofer  
H:844 W:500 D:186mm

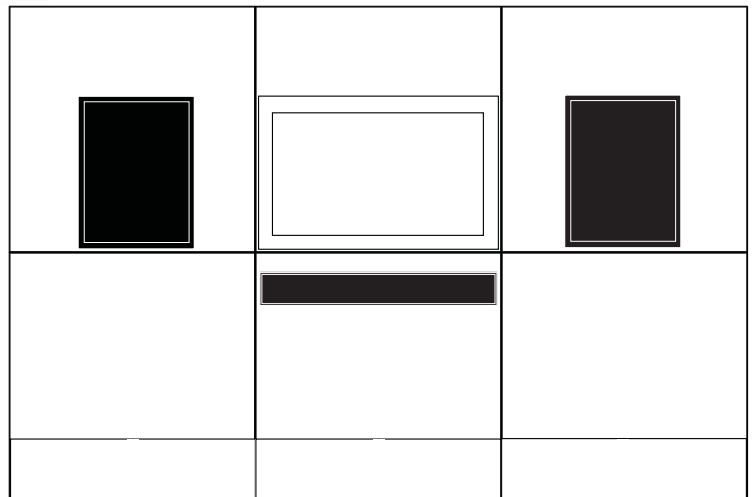

Media Walls  
Single plate: H:1060 W:1060 D:28mm (Illustration above includes 6 plates total)





**Artcoustic's unique 160 degree ultra-wide-axis Target lens design and X2 subwoofer technology.**

With the Artcoustic ultra-wide-axis Target lens technology, the Artcoustic SUPERSTAR provides the listener with near perfect acoustics even in the most demanding listening environment. Coupled with the advanced Artcoustic X2 subwoofer technology and a 2x150watt amplifier, the listener will experience powerful and detailed sound, normally only achieved by a much bigger and complex system.



# SUPERSTAR Accessories, source and fitting instructions

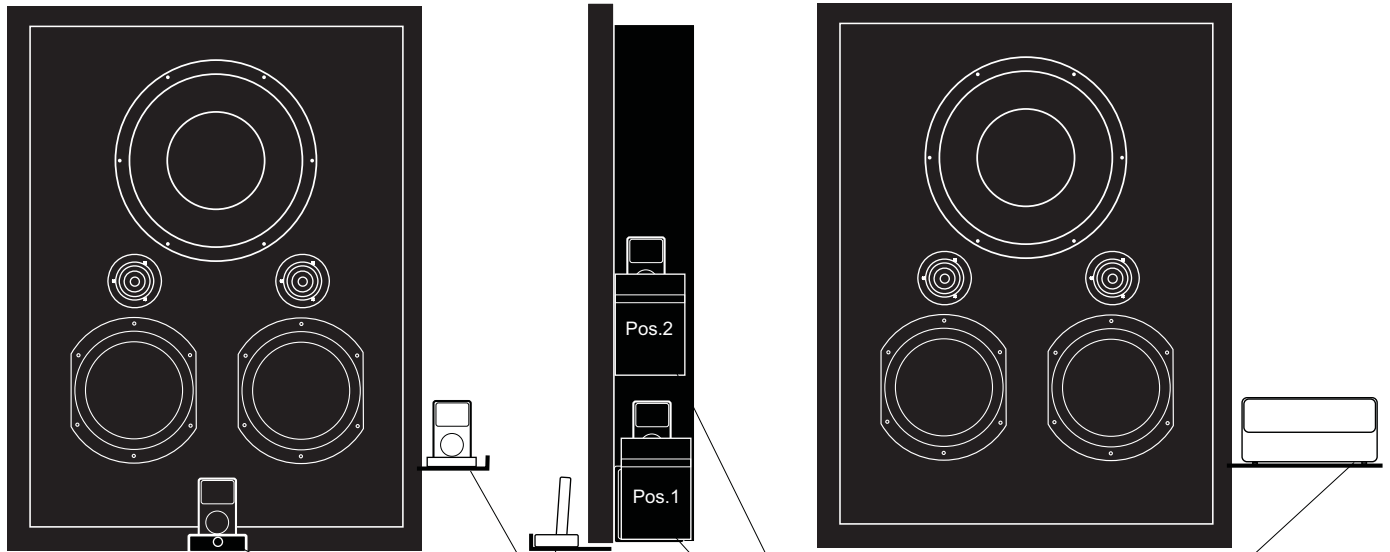

## Source Options

The SUPERSTAR comes with three shelf options to accommodate your chosen source. Mount the shelf which best suits your source using the screws supplied.

### Shelf 1

Front or side mounting option. Ideal for small – medium digital source and docking station

### Shelf 2

Side mounting only. This pocket design is ideal for sources such as mobile phones without docking stations

### Shelf 3

Side mounting only. Large shelf for larger sources

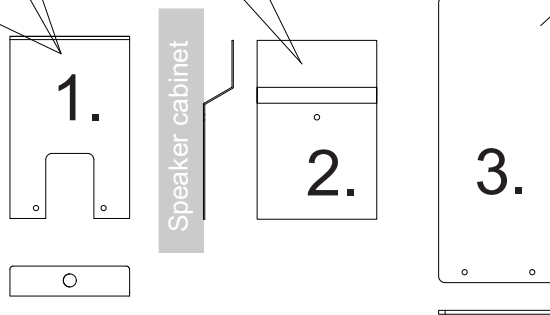

We highly recommend the use of a purpose designed docking station no matter what the type or brand of MP3 player, or other source.

**Note** that by using the mini jack straight out of the source, the audio output in some cases will be limited. In most cases this can be eliminated by using a docking station or a purpose made output connector, such as a multi pin connector to RCA.

the SUPERSTAR is compatible with any digital source, including:

iPod®, iPhone®, AirPort Express®, Archos®, Sonos®, Squeezebox®, Bose®, B&O®

## SUPERSTAR adjustable wall mount bracket

### Fitting Instructions:

Using screws and fixings suitable for your wall type (not supplied) mount the Wall Bracket to the desired height.

Decide where the top of your SUPERSTAR should be and measure down for the wall bracket position, the screw holes of the wall bracket are 126mm from the top of the SUPERSTAR. Once the Wall Bracket is securely fixed hook the Speaker Bracket over the Wall Bracket. The curved edge of the Speaker Bracket allows for levelling adjustment – take the weight of the SUPERSTAR and then carefully straighten the unit. Once straight release the unit and the bracket locks in to place.

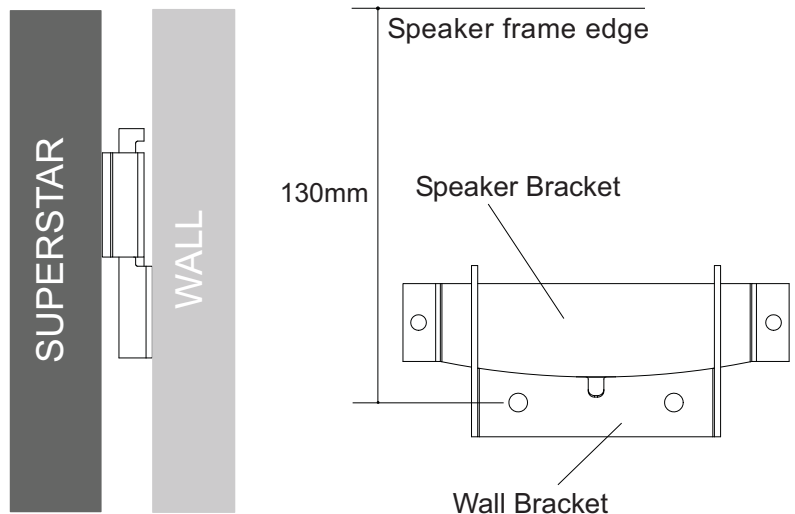

# SUPERSTAR Music Centre

Cabinet colour



Black

Screen options

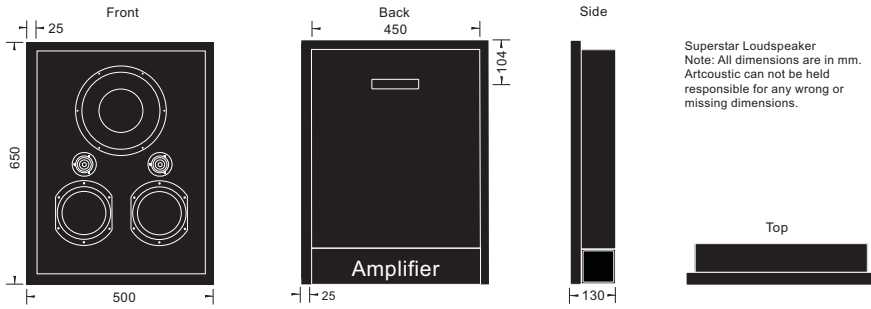
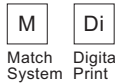

## Artcoustic SUPERSTAR

An all-in-one stereo music centre with state-of-the-art superb sound quality and endless design options. Your music should sound amazing every time you play it and with the SUPERSTAR you hear every detail as intended! The SUPERSTAR is the latest product in the Artcoustic range and unlike other all-in-one high-end systems, the SUPERSTAR is compatible with any digital source. It is very easy to use – simply plug in your source and play. The interchangeable front screen gives you the freedom to choose the look of the front of the speaker, to personalise your SUPERSTAR and complement your interior, then change it when ever you like!

## SUPERSTAR

3-way full range active music centre with built-in subwoofer. 2 x 5.5 inch LF-MF units, 2 x 1.5 inch 90 degree X2 HF unit, 1 x 10" subwoofer and a 2x150watt amplifier into 8ohm. All screen options are available for the SUPERSTAR: The Match System / Digital Prints.

- Operating Range:  30 Hz to 40 KHz
- Beamwidth HF:  90 degree X2 with Target lens 160 degree
- FR:  SPL 1 Watt 93dB Max SPL 106 dB SPL avg 4 ohm continuous power handling 120 W
- LF:  Max SPL 106 dB SPL avg 4 ohm continuous power handling 120 W
- HF:  Max SPL Switch setting (0) 106 dB.  
continuous power handling 100 W
- Connections:  Active
- Dimensions:  650 H x 500 W x 130 D mm.
- Weight:  18 kg each

## Applications

2-channel stereo max SPL 1m 106dB max SPL 4m 102dB	Suitable
Restaurant - Bar - fixed installation - boardroom, auditorium max SPL 1m 106 dBmax SPL 4m 102dB	Suitable

## Superb sound and great design!

Artcoustic has produced some of the best loudspeakers in the world. The company is at the forefront of technological innovations to bring you the best audio solutions possible. The SUPERSTAR is the first of its kind and is an icon of Artcoustic's innovative product development.

### Applications:

Residential: Bedroom, Kitchen, Lounge and Living Area, Study, Games and Recreation Room

Commercial: Café, Bar, Restaurant, Reception, Office, Hotel Room, Gymnasium

The SUPERSTAR can be used as a stand alone unit or linked together as a multi-room system solution.

### Technical Specifications amplifier, also see PA-260 amplifier manual:

- Amplifier 2 x 150watt into 8ohm
- Optional cooling fan
- Bass Eq. @ 45Hz flat, +3dB, +6dB
- Crossover, full range, 80Hz. 120Hz.
- Bridged, mono and stereo switch
- RCA left and right input terminals
- DIN input (Bang & Olufsen ready)
- Auto turn on/turn off
- Input sensitivity volume control
- iPod USB charger

## Artcoustic PA-260 2 channel amplifier (bridged mono block) features

- Only 2 rack units high, means It has a very high output while occupying
  - minimal rack space.
- input sensitivity control.
- Signal presence and protection indicator.
- Unbalanced input via RCA connectors, DIN input (Bang & Olufsen)
- USB charger (iPod)
- Stable performance down to 4 ohms.
- Auto turn on, turn off - signal sensing
- Stereo, mono or bridge mode switch
- 45Hz. Eq. 0dB. +3dB +6dB
- Subwoofer crossover, full range, 80Hz. and 120Hz. 18dB. per octave
- High current bi-polar technology.
- Precision subharmonic filters.
- Dual monoblock amplifier PCB design, bridge mode.
- Extended protection circuit.
- High efficiency switching supply, multi voltage 110V. to 230V.
- Dual fan speed, setting 0 residential = silent, setting 1 commercial = full fan speed
- Totally protected against overheating and shorting and includes DC prevention at the □ output stage.
- 3 year guarantee.

**Most importantly, the PA-260 has been designed and engineered to match the Artcoustic loudspeaker's impedance and tonality, making them perfect partners.**

## PA-260 Technical Specification

### Output power 20Hz-20KHz RMS program channel

4 ohm □ 180 WRMS

8 ohm □ 130 WRMS

### Output power 20Hz-20KHz RMS program bridged

8 ohm □ 300 WRMS

Recommended impedance 8 ohm

### Input sensitivity

RCA unbalanced 600mV/1kOhm

DIN (Bang and Olufsen) 600mV/1kOhm

S/N ratio channel 89dB

Frequency response: 20Hz -20KHz

THD <0.05%

Damping factor @ 8 ohm > 600

Crosstalk > 45dB

Slew rate 30V/ms.

Power: 115V/230V ac 360VA

Protection, heat, DC, short cut and soft start

Dimensions (H x W x D) : 89 x 484 x 92mm

Weight : 4Kg



Black

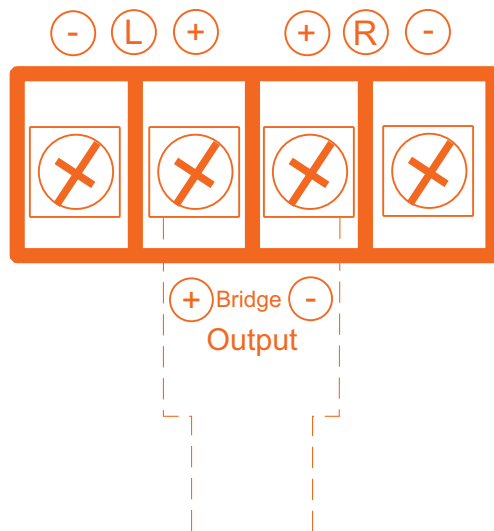

Bridge mode output mainly used in conjunction with the Artcoustic Diablo Panel Subwoofer

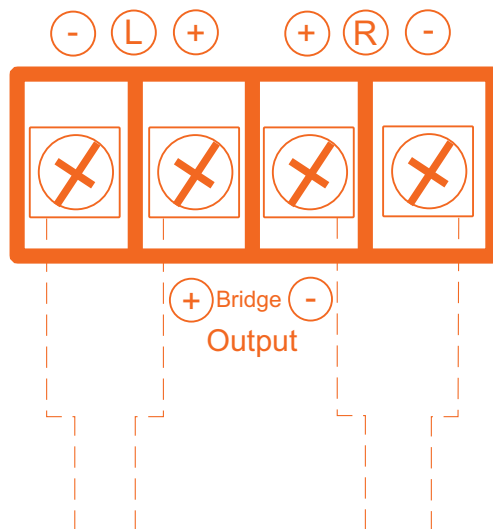

Typical stereo connection for all purpose use, such as a stereo sound system or multi room speaker system  
(If switch is set to mono, the left and right channel will be combined and both channel will output identical signal)

## Important!

- Always check for correct polarity on speaker wires
- Always turn off the amplifier before connecting speaker cables
- Always turn off the amplifier before using any of the filters, crossover, bass EQ. stereo, bridge and mono
- Never use bridge mode with speakers below 4ohms
- Always set the fan setting to **on**, if used demanding applications such as commercial installations

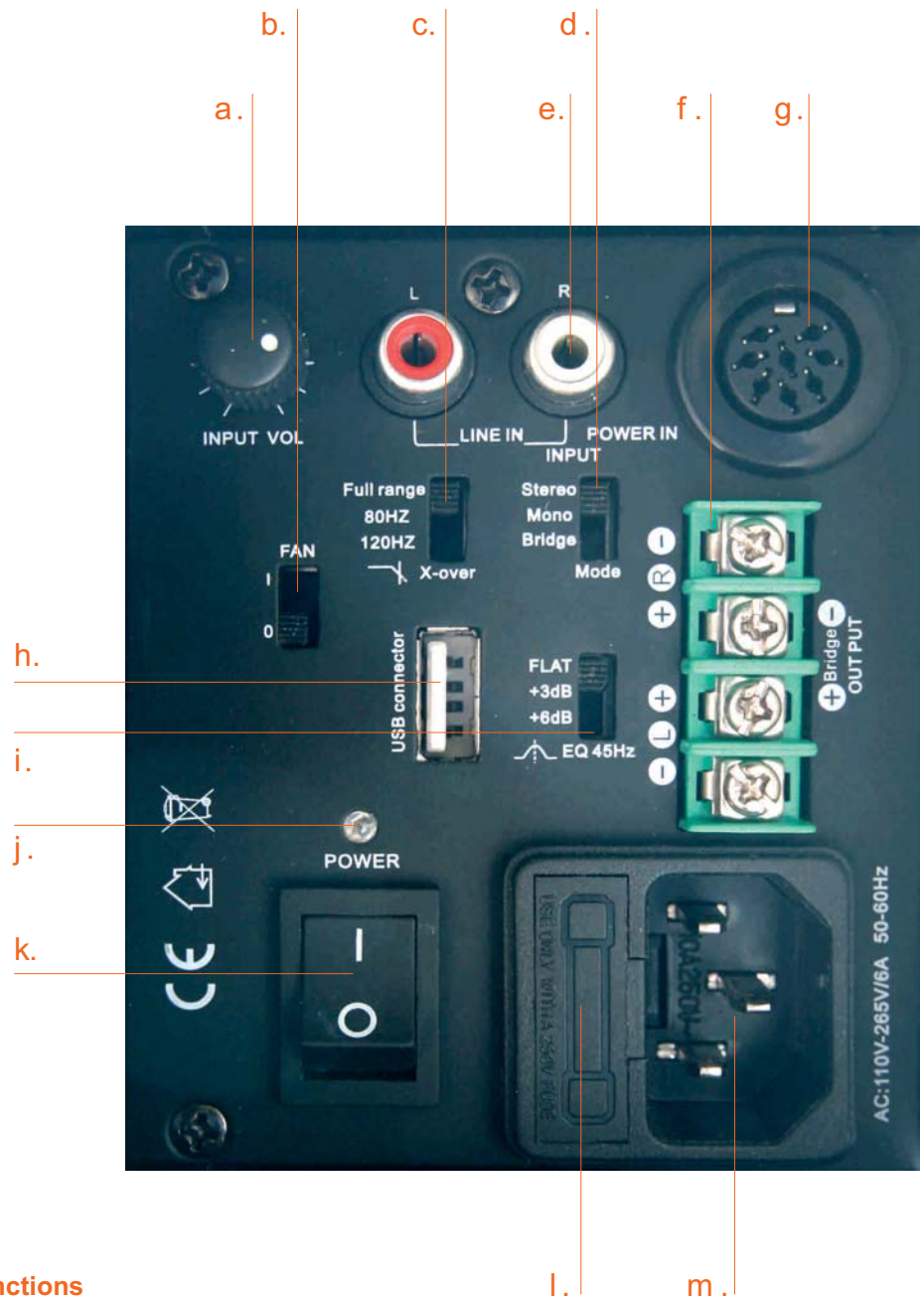

## PA-260 Power Amplifier Functions

- a. Master volume control
- b. Cooling fan on/off
- c. Subwoofer crossover, full range, 80Hz. and 120Hz. cut high frequency cut 18dB per octave
- d. Stereo, mono and bridge mode setting (do not use bridge mode setting with Superstar)
- e. RCA unbalanced audio input, left and right channel
- f. Speaker output terminals, stereo and bridge mode
- g. Bang and Olufsen DIN input
- h. USB iPod battery charger
- i. EQ. @ 45Hz. flat, +3dB. +6dB bass boost
- j. Power on/off LED indicator
- k. On/off main switch (PA-260 are equipped with a automatic power on/off function, so no need to turn the amplifier off on main switch)
- l. Main power fuse
- m. Main power input socket (Auto voltage selector 110V. to 230V.)

HEADQUARTER  
HOLMENS KANAL 7  
1060 COPENHAGEN K  
DENMARK

TEL: ☐ +45 3283 6060

FAX: ☐ +45 3283 6064

@: [artcoustic@artcoustic.com](mailto:artcoustic@artcoustic.com)

[www.artcoustic.com](http://www.artcoustic.com)



**ARTCOUSTIC**<sup>™</sup> Loudspeakers